

Best of

#1/2024

New products and top promotions

Cordless. Limitless.

Promotions are valid until 31 August 2024.
Only while stocks last and only from participating dealers!

NEW! FLEX now for the garden tools

Practical garden tools with 18 V battery power

→ Page 2

NEW! 18 V cordless metal band saws

Perfectly balanced!

→ Page 7

FLEXPACK

Now only € 799.00 plus VAT

→ Page 13

FLEX
this is performance

FLEX now for the garden too

Cordless leaf blower GBL 790 18-EC



- Compact design, the lightest tool in its class, with 125 Ø mm air flow tube that can be removed without tools
- Air volume regulation in 3 stages with Boost mode for clearing leaves in small to medium-sized areas
- Compact and ergonomic design
- Ergonomically shaped soft handle with on/off switch and lock mechanism for continuous operation
- The electronic management system (EMS) protects the tool, extends its service life and increases efficiency

NEW

FLEX
pack

Order No. 531278

- 1x GBL 790 18-EC

Promotion No. 01

1.740⁰⁰



Cordless chainsaw GCS 35 2x18-EC



- Powerful 2 x 18 V cordless chainsaw with a 35 cm saw bar for fast cutting, e.g. for delimiting and in wood up to approx. 30 cm
- The sturdy metal claw fence fixes the saw to the wood, making it easy to make cuts safely
- With recoil brake, stops the chain reliably in 0.12 seconds and transport lock
- With tool-free chain tensioning via rotary wheel and automatic chain lubrication

NEW

FLEX
pack

Order No. 531276

- 1x GCS 35 2x18-EC

Promotion No. 02

2.690⁰⁰



Cordless hedge trimmer GHT 55 18-EC



- Lightweight and powerful hedge trimmer with rotating handle for optimum handling
- Bar length 55 cm, very powerful thanks to the double-sided dual-action laser-ground blade with a cutting capacity of 25 mm. The additional impact protection prevents the blades from being damaged by fences or walls.
- With a safety double switch to prevent unintentional start-up of the hedge trimmer and an additional hand guard
- Electronic brake stops the tool in 3 seconds

NEW

FLEX
pack

Order No. 531275

- 1x GHT 55 18-EC

Promotion No. 03

1.740⁰⁰

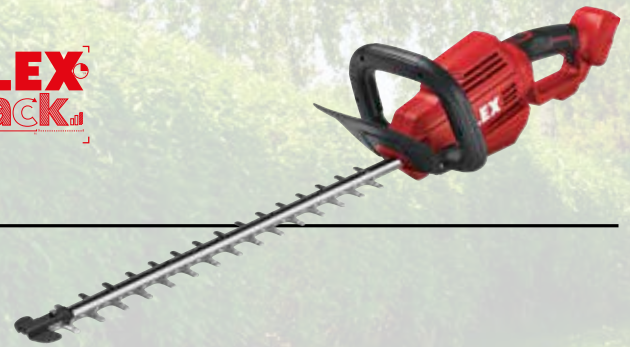

Cordless lawn trimmer GLT 35 18-EC

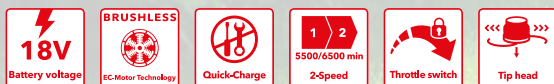

- Powerful cordless lawn trimmer with a high cutting speed in 2 stages, for trimming green areas, removing tall grasses and light undergrowth, cutting width 30 cm.
- Thread head with "Easy load" - simple adjustment of the thread length by means of automatic inching. With thread cutter and spray guard
- Compact and ergonomic design
- With accelerator trigger switch and continuous operation function

NEW

FLEX
pack

Order No. 531277

- 1x GLT 35 18-EC

Promotion No. 05

1.940⁰⁰



Does what it promises

18 V cordless vacuum lifter VLP 18 Grabo

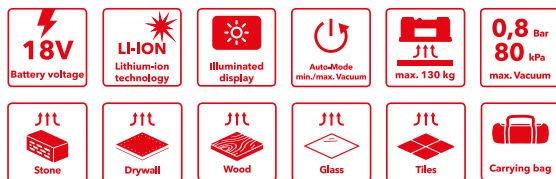

NEW

- The ergonomically-designed, portable electric vacuum lifter lifts and moves almost any object and puts it effortlessly into place. This vacuum lifter is ideal for various materials such as tiles, drywall panels, concrete blocks, glass, metals, furniture and large electrical appliances.
- Its powerful functionality ensures that heavy objects are handled both efficiently and reliably.
- The vacuum lifter has a holding force of up to 170 kg and sucks on almost any surface, even dusty, rough or semi-porous materials.
- Work safety has the highest priority. The vacuum lifter has an automatic suction function and the digital display continuously provides information about the current negative pressure
- With a powerful vacuum pump, stops automatically at maximum vacuum
- The electronic management system (EMS) protects the tool, extends its service life and increases efficiency

TECHNICAL DATA VLP 18 GRABO

Rated air flow	20 l/min
Max. vacuum	0.8 bar
Max. load-bearing capacity	130 kg
Max. holding force	170 kg
Working temperature	0 °C ~ 60 °C
Dimensions L x W x H	300 x 184 x 121 mm
Battery voltage	18.0 V
Battery capacity	2.5 / 5.0 / 8.0 Ah
Weight without battery pack	1.48 kg

Order No. 531330

- 1x VLP 18 Grabo
- 1x protective bag

Promotion No. 05
3.900⁰⁰



Also available as a kit in L-BOXX® (Order No. 531492) and as a complete kit including batteries and charger in L-BOXX® (Order No. 531332).



The VLP 18 GRABO has a digital display that shows the maximum liftable weight in pounds or kg.



The VLP 18 Grabo has four metal anchor points for external attachment and additional lifting options.

18 V cordless metal shears SHE 16 18-EC



- Brushless motor
- Speed preselection in 4 steps, CDC constant electronics, soft start, overload protection, restart lock, temperature monitoring
- Anti-kickback, switches off the motor if the tool gets jammed
- Maximum curve mobility and convenient cutting of tight radii from 15 mm
- Burr-free cutting of metal sheets and blade spacing flexibly adjustable to different sheet thicknesses
- Extremely streamlined handle section with soft-grip inlays
- Maximum work safety thanks to large hand guard
- 4 HSS reversible blades: The blades are reversible and can be used 4 times

TECHNICAL DATA SHE 16 18-EC

Stroke rate at no-load	950 - 2050 rpm
Max. metal sheet thickness, steel 400 N/mm ²	1.6 millimetres
Max. metal sheet thickness, steel 600 N/mm ²	1.2 mm
Max. metal sheet thickness, steel/stainless steel 800 N/mm ²	1.0 mm
Max. metal sheet thickness, aluminium 250 N/mm ²	2.0 mm
Smallest radius	16 mm
Min. starting hole diameter	27 mm
Diameter of smallest cuttable hole	50 mm
Working speed	5-9 m/min
Battery voltage	18.0V
Battery capacity	2.5 / 5.0 / 8.0 Ah
Weight without battery pack	1.5 kg

NEW

Order No. 531583

- 1x SHE 16 18-EC

Promotion No. 06
5.490⁰⁰



18 V cordless nibbler KNE 16 18-EC



- Brushless motor
- Speed preselection in 4 steps, CDC constant electronics, soft start, overload protection, restart lock, temperature monitoring
- Anti-kickback switches off the motor if the tool gets jammed
- Good curve mobility for notches and internal cut-outs from radii of 40 mm or more
- Quick, tool-free adjustment of the cutting direction up to 360° in 45° increments
- Extremely streamlined handle section with soft-grip inlays
- Cutting with no distortion and sparks

TECHNICAL DATA KNE 16 18-EC

Stroke rate at no-load	1950 - 4250 rpm
Max. metal sheet thickness, steel 400 N/mm ²	1.6 mm
Max. metal sheet thickness, steel 600 N/mm ²	1.0 mm
Max. metal sheet thickness, steel/stainless steel 800 N/mm ²	0.7 mm
Max. metal sheet thickness, aluminium 250 N/mm ²	2.0 mm
Smallest radius	24 mm
Min. starting hole diameter	22 mm
Diameter of smallest cuttable hole	48 mm
Distance for template cutting	1.5 mm
Working speed	2.2m/min
Battery voltage	18.0V
Battery capacity	2.5 / 5.0 / 8.0 Ah
Weight without battery pack	1.5 kg

NEW

Order No. 531584

- 1x KNE 16 18-EC

Promotion No. 07
5.790⁰⁰





Compact orbital sander with speed control OSE 2-70x198-EC



- E-signal switch for simple, safe operation with quick-stop function prevents the backing pad from coasting
- Grinding speed suitable for the material thanks to electronic speed adjustment
- Ideal for sanding filled surfaces on car parts during repair work. For surface sanding the substrate and avoiding unevenness before applying the filler and using a random orbit sander
- Electronics: Speed preselection in 4 steps, tachometer-controlled constant speed, soft start, restart protection
- Velcro backing pad with bevelled pad geometry and multi-hole system for optimum suction, suitable for all commercially available pads
- Lightweight, compact single-hand orbital sander, very ergonomic and low-vibration thanks to special balancing for fatigue-free work that's easy on the joints
- Effective dust extraction thanks to integrated self-extraction for dust-free working with filter cartridge
- Option to connect an external dust extractor with Ø 27 mm, anti-static suction hose SH 27x3.5m AS (445.045)

NEW



With extra-large backing pad!

Order No. 530632

- 1x OSE 2-70x198-EC
- 1x Velcro backing pad SP 70x198-M

Promotion No. 08

2.790⁰⁰

Cordless edge milling cutter and router CER 18-EC



- An edge milling cutter and router combined. Toolless conversion from the edge cutter to the router
- The collet can be used for milling cutters with a shank diameter of up to 8 mm
- With scale zero function, milling depth adjustment via turret stop and infinitely variable milling depth fine adjustment via rotating ring
- The milling table with rubber-coated handles and clamping function enables safe guidance. The Plexiglas base plate always gives the user a clear view of the milling cutter for perfect results
- For a wide range of applications in woodworking, renovation, drywall construction and mould making. Milling of corner joints, joints, curves/contours with templates, re-milling of laminate profiles. Milling solid wood edges, recesses and grooves with templates and guide rings, making templates for production, etc.
- Electronic quick-acting brake
- Connector for external dust extraction Ø 36 mm or step adapter

NEW

FLEX[®] pack



Also available as a 2.5 Ah kit in L-BOXX[®]

4.780,-
(Order No. 531635)

and as a 5.0 Ah kit including batteries and charger in L-BOXX[®]

5.490,-
(Order No. 531636)

TECHNICAL DATA CER 18-EC

Idling speed	16,000 - 31000 rpm
Collet diameter	8 mm
Milling stroke (depth)	50 mm
Sound pressure level in acc. with EN 60745	78 dB(A)
Vibration in acc. with EN 60745	1.5 m/s ²
Battery voltage	18.0V
Battery capacity	2.5 / 5.0 / 8.0 Ah
Weight without battery pack	1.8 kg

Order No. 531634

- 1x CER 18-EC
- 1x open-end spanner a/f 17
- 1x base plate D-Format CER
- 1x quick-action stop PG CER
- 1x base plate, round SBB CER
- 1x dust extraction guard SG CER
- 1x collet SPZ CER D6.35
- 1x collet SPZ CER D8

Promotion No. 09
2.240⁰⁰



Variable speed adjustment (6 settings).



Quick and easy cutter change thanks to integrated spindle lock.



An edge milling cutter and router combined. Toolless conversion from the edge cutter to the router.



Integrated LED lamp for optimum illumination of the work area.

Cordless band saw SBE 64 18-EC

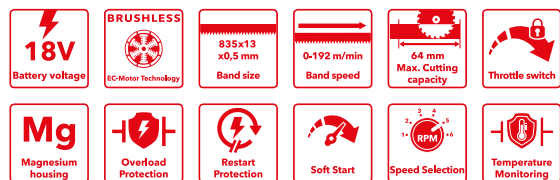

- A perfectly balanced band saw thanks to its design, supported by optimum weight distribution of the battery and motor.
- The SBE is particularly suitable for spark-free cutting of metal in environments where there is a risk of fire
- Brushless motor with greater efficiency and a longer service life
- Adjustable belt speed for perfect cuts in a variety of materials
- Toolless saw blade changing
- Integrated LED lamp for optimum illumination of the work area.
- Ergonomically designed, non-slip rubber-coated handle
- With metal bracket for flexible attachment
- The electronic management system (EMS) protects the tool, extends its service life and increases efficiency



Tool-free saw blade change, with an additional saw blade cover providing increased safety during use.



Adjustable blade speed for perfect cuts in a variety of materials.



Order No. 531748

- 1x SBE 64 18-EC
- 1x bimetallic saw blade
- Carrying case TK-L 238



Promotion No. 10

2.590⁰⁰

Cordless band saw SBE 127 18-EC

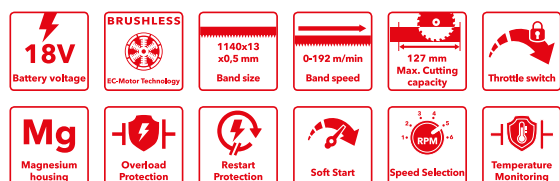

- A perfectly balanced band saw thanks to its design, supported by optimum weight distribution of the battery and motor.
- The SBE is particularly suitable for spark-free cutting of metal in environments where there is a risk of fire
- Brushless motor with greater efficiency and a longer service life
- Adjustable blade speed for perfect cuts in a variety of materials
- Tool-free saw blade change, with an additional saw blade cover providing increased safety during use
- Integrated LED lamp for optimum illumination of the work area.
- Ergonomically designed, non-slip rubber-coated handle
- With metal bracket, non-slip for flexible attachment
- The electronic management system (EMS) protects the tool, extends its service life and increases efficiency



Order No. 531749

- 1x SBE 127 18-EC
- 1x bimetallic saw blade
- 1x carrying case



Promotion No. 11

4.190⁰⁰

FLEX
STACK
PACK™

Workshop to go

Everything ready to go, everything to hand: The FLEX STACK PACK™ is the mobile workshop in trolley form, offering you many individual configuration options. The toolbox of today.



Removable handle

Quick release

Metal latch

Aluminium-reinforced corners with fastening interface

Front handle

Cable wrap TKH KW (accessory)

All boxes in Protection Class IP65

Tool holder rails Side TKH WS (accessory)

Robust wheels Ø 23 cm

Spirit level holder TKH ADL (accessory)



The all-round package for all jobs

TK-L SP KIT 1

STACK PACK™

value kit consisting of

- Roller Box TK-L SP RB
- Medium Box TK-L SP BO
- Big Organizer TK-L SP BO

Order No. 531461

Promotion No. 12

3.190⁰⁰



Now at a value price!

Small Organizer TK-L SP SO

- 11 kg loading capacity
- Clear, transparent cover
- Incl. four accessory containers with partitions

Order No. 531468

Promotion No. 13

390⁰⁰



Big Organizer TK-L SP BO

- 22 kg loading capacity
- Incl. eight accessory containers with partitions

Order No. 531467

Promotion No. 14

690⁰⁰



Top Box TK-L SP TB

- 50 kg loading capacity
- Incl. four accessory containers with partitions

Order No. 531466

Promotion No. 15

790⁰⁰



Roller box TK-L SP RB

- Robust tyres Ø 23 cm
- 110 kg loading capacity
- Universal hook
- Removable handle
- Incl. removable accessory container
- Gas pressure springs

Order No. 531464

Promotion No. 16

1.890⁰⁰



Medium Box TK-L SP BO

- 63 kg loading capacity
- Incl. removable accessory container
- Metal-reinforced folding handle
- Gas pressure springs

Order No. 531465

Promotion No. 17

1.050⁰⁰



Cable wrap TKH KW



Order No. 531472

Promotion No. 18

190⁰⁰

41-part bit kit DB 41

- Variable content set-up
- FLEX STACK PACK™ stackable inside and on top of each other
- Easy opening with a button
- Fixed locking of the stacking function

Order No. 530494

Promotion No. 19

450⁰⁰



Empty box also available (Order No. 530535).

25-piece bit kits

- ⊕ **DB Bulk PH2**
Order No. 530489
Promotion No. 20
- ⊕ **DB Bulk T20**
Order No. 530490
Promotion No. 21
- ⊕ **DB Bulk T25**
Order No. 530491
Promotion No. 22
- ⊕ **DB Bulk T30**
Order No. 530492
Promotion No. 23
- ⊕ **DB Bulk T40**
Order No. 530493
Promotion No. 24

Order No. see left

Promotion No. 20-24

105⁰⁰



Spirit level holder TKH ADL



Order No. 531469

Promotion No. 25

190⁰⁰

Tool holder rails Side TKH WS



Order No. 531471

Promotion No. 26

400⁰⁰

With XLITHIUM POWER PLUS

18 V battery pack with 8.0 Ah. Additional performance and longer run times for more performance.

THERMA-TECH™
**X LITHIUM
POWER PLUS**

+ Power

The higher energy density of 8.0 Ah battery allows up to 75% more power for selected products.*



+ Run time

The modern cell technology delivers a run time up to 60% longer.*

* compared with AP 18.0/5.0 Ah

** - Cordless compact circular saw with pendulum hood CS 62 18.0-EC
- 2-speed cordless hammer drill driver with Turbo mode PD 2G 18.0-EC HD
- Cordless mitre saw SMS 190 18.0-EC

+ Service life

Therma-Tech™ technology absorbs the heat generated, ensuring longer battery run times and life cycles. Keep Control manages the strong power output while protecting the battery pack.

Li-ion battery packs

Integrated charge and discharge protection
Protected against dust and splash water
Integrated charge indicator. Shows at a glance the charge of the battery cells.

AP 18.0 V



Order No.	445886	445894	521078
AP 18.0 V	2.5 Ah	5.0 Ah	8.0 Ah
Price	776,00	1.214,00	2.030,00

AP 10.8 V



Order No.	418048	439657
AP 10.8 V	2.5 Ah	4.0 Ah
Price	602,00	725,00

3 YEARS
FLEX WARRANTY

3-year warranty
Also applies to battery packs and chargers.

See reverse for details

P-Kit 55 R

- Charging station 10.8/18.0 volt
- 2x battery packs 5.0 Ah 18,0 V



Order No.	491349
Price	2.550,00

P-Kit 22 Q

- Charging station 18.0 volt
- 2x battery packs 2.5 Ah 18,0 V



Order No.	491357
Price	1.590,00

The patented Proformance battery system delivers what it promises!

Long run time, long service life, long maximum performance. Only from FLEX With the patented cooling system, FLEX delivers optimum protection of the tool and the battery cells. The battery management system controls the permanent data exchange between the tool, battery and charger so that all parameters are optimally set. This ensures power when the battery and tool are working together, and allows use without energy loss.



Keep Control

The smart technology controls and monitors the tool activity and the charging process, and provides information on the charging status via the LCD display.



Therma-Tech™

The unique, integrated cooling system ensures constant temperatures even under heavy loads.



Power battery

Powerful Li-Ion cells provide 18 V power.



Lithium-ion

No self-discharge. No memory effect.



EC motor

Low-wear and brushless motor with EC technology for greater running performance, more power and more life



Cordless tool

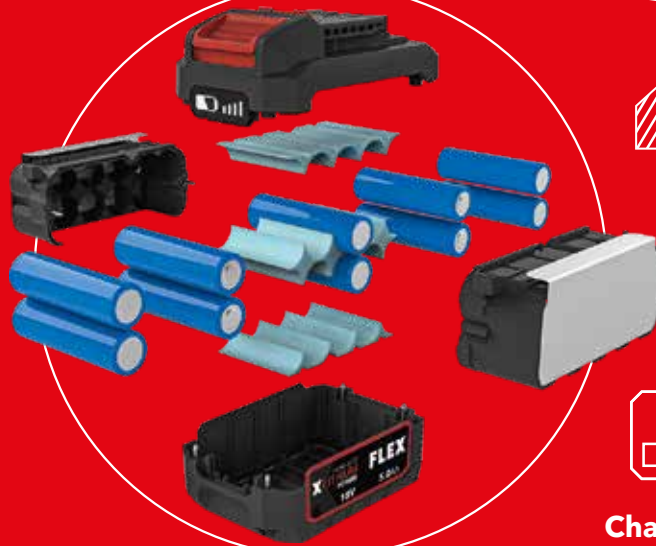

Therma-Tech™ technology



Charger



Charger CA 10.8

- for 10.8 V battery packs
- Integrated battery pack cooling, overheating, discharge and overload protection
- With LED charge indicator



Order No. **418021**
 Price _____
 Charging times, 10.8 V batteries

- 40 min for 2.5 Ah battery pack
- 50 min for 4.0 Ah battery pack

Charger CA 10.8 / 18.0

- for 10.8 V and 18.0 V battery packs
- Integrated battery pack cooling, overheating, discharge and overload protection
- LCD display



Order No. **417882**
 Price _____
 Charging times, 18.0 V batteries

- 40 min for 2.5 Ah battery pack
- 50 min for 5.0 Ah battery pack



The large-format LCD display with a charge time and charge indicator shows the remaining charge time.



FLEX

pack

RV



3
YEARS
FLEX WARRANTY

18V
Battery voltage

BRUSHLESS
EC-Motor Technology



Now even more choice!

Select your 3 new 18 volt units from the wide FLEX cordless range and make savings not just on the tools: Each FLEX PACK includes three battery packs, a charger and a bag for free. So take what you want. The choice is yours!

3 tools of your choice

The FLEXPACK contains:



Rechargeable battery kit

3x Li-ion battery packs
AP 18.0/5.0 Ah
1x rapid charger
CA 10.8/18.0



Bag

1x practical carrying bag made of plastic-reinforced, tear-resistant fabric material



Even cheaper thanks to the FLEX Power promotion!

When ordering, please state the following FLEXPACK order number in addition to the listed unit order numbers.

497444

5.600⁰⁰

3 units of your choice

You can choose more than one of the same tool.



Order No. 491292
4-speed cordless drill driver
DD 4G 18.0-EC C **1**



Order No. 491225
2-speed cordless drill driver
DD 2G 18.0-EC C **1**



Order No. 530531
2-speed cordless drill driver
DD 2G 18.0-EC LD **1**



Order No. 491233
2-speed cordless hammer
drill driver
PD 2G 18.0-EC C **1**



Order No. 530189
Cordless impact driver
IW 1/2" 950 18.0-EC C **1**



Order No. 491268
Cordless impact driver
IW 1/2" 18.0-EC C **1**



Order No. 520756
Cordless impact driver
ID 1/4" 18.0-EC-HD C **1**



Order No. 492612
Cordless impact driver
IW 3/4" 18.0-EC C **1**



Order No. 491276
Cordless drywall screwdriver
DW 45 18.0-EC C **1**



Order No. 517674
Cordless circular saw
CS 45 18.0-EC C



Order No. 491322
Cordless circular saw
CS 62 18.0-EC C **3**



Order No. 504491
Cordless basic motor
TRINOXIFLEX
BME 18.0-EC C **2**



Order No. 518867
Cordless straight grinder
DGE 25 18.0-EC **1**



Order No. 489794
Cordless jigsaw
JSB 18.0-EC C **1**



Order No. 485403
Cordless jigsaw
JS 18.0-EC C **1**



Order No. 513075
LED cordless lamp
WL 300 18.0



Order No. 530610
LED cordless lamp
WL 1000 18.0



Order No. 504637
LED cordless lamp
WL 2800 18.0



Order No. 472921
LED cordless building site
spotlight CL 2000 18.0



Order No. 486728
LED cordless full-spectrum
lamp DWL 2500 10.8/18.0



Order No. 504610
LED cordless lamp
CL 10000 10.8/18.0



Order No. 504602
LED cordless lamp
CL 5000 10.8/18.0



Order No. 530375
LED cordless building site
spotlight TL 4000 18.0/230



Order No. 481491
Cordless compact vacuum
cleaner VC 6 L MC 18.0



Order No. 509981
Cordless compact vacuum
cleaner
VC 2 L MC HIP 18.0-EC



Order No. 506648
Cordless inflator
CI 11 18.0/12V



Order No. 472913
Cordless fan BW 18.0-EC



Order No. 503002
Cordless fan CF 18.0/230



Order No. 530372
Cordless reciprocating saw
RS 25 18.0 C **1**



Order No. 515981
Cordless reciprocating saw
RS 29 18.0 C **2**



Order No. 491306
Cordless reciprocating saw
RSP DW 18.0-EC C **2**



Order No. 531748
Cordless band saw
SBE 64 18-EC **2**



Order No. 495964
2-speed cordless mixer
MXE 18.0-EC WR2 120
incl. WR2



Order No. 531277
Cordless lawn trimmer
GLT 35 18-EC



Order No. 531278
Cordless leaf blower
GBL 790 18-EC



Order No. 531276
Cordless chain saw
GCS 35 2x18-EC



Order No. 531275
Cordless hedge trimmer
GHT 55 18-EC



Order No. 531634
Cordless edge milling cutter
and router
MT 18.0-EC C **2**



Order No. 484857
Cordless construction site
radio RD 10.8/18.0/230



Order No. 521078
18 V battery pack
AP 18.0/8.0

FLEX pack



3-year warranty
Also applies to battery packs and chargers.
 For details, see page 35



Order No. 515698
 2- Cordless hammer drill driver with Turbo mode PD 2G 18.0-EC-HD C **1**



Order No. 531272
 2-speed cordless drill driver with Turbo mode DD 2G 18.0-EC HD C **1**



Order No. 530532
 2-speed cordless hammer drill driver PD 2G 18.0-EC LD **1**



Order No. 530231
 Cordless impact driver IW 1/2" 750 18.0-EC C **1**



Order No. 531311
 Cordless combination rotary hammer drill FHE 1-16 18.0-EC C



Order No. 491284
 Cordless combination rotary hammer drill CHE 18.0 EC C **2**



Order No. 491314
 Cordless rotary hammer drill CHE 2-26 18.0 EC C **2**



Order No. 518409
 Cordless Multitool 18.0 V with StarlockMAX holder MT 18.0-EC C **1**



Order No. 499307
 Cordless angle grinder LB 125 18.0-EC C **1**



Order No. 499285
 Cordless angle grinder LBE 125 18.0-EC C **1**



Order No. 530497
 Cordless angle grinder L 125 18.0-EC LD C **1**



Order No. unisex

M	417998
L	423165
XL	423173

Battery-operated heated jacket TJ 10.8/18.0



	men	women
XS	-	512052
S	512176	512060
M	512168	512079
L	512141	512192
XL	512184	512095
XXL	512125	512109
3XL	512117	-

Battery-operated heated jacket, fleece TF White 10.8/18.0



	men	women
XS	-	512044
S	511919	512036
M	511927	512028
L	511935	512001
XL	511943	511994
XXL	511951	511986
3XL	511978	-

Battery-operated heated jacket, soft shell TJ White 10.8/18.0

Ideal supplement to the FLEXPACK

The promotion applies only when purchasing three L-BOXXes!



Economy box kit

Choose three L-BOXXes from the sizes

- 1** TK-L 136 (507822, Promotion No. 27)
- 2** TK-L 238 (507830, Promotion No. 28)
- 3** TK-L 374 (507849, Promotion No. 29)

and get a bonus matching anti-slip inlay for each

- L-BOXX®
- 3x anti-slip inlay

Promotion No. 27-29

1.450⁰⁰

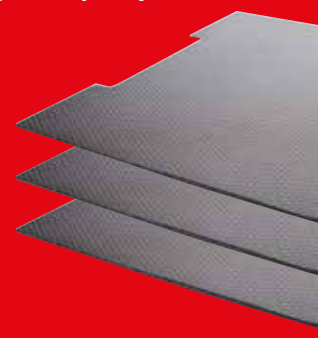

Example combination of TK-L 136, TK-L 238 and TK-L 374

You need them on every construction site.

18 V cordless angle grinder L 125 18.0-EC LD/5.0 kit



- Brushless motor with greater efficiency and a longer service life
- Extremely streamlined handle section with soft-grip inlays
- Microprocessor control with soft start, restart protection after power failure, overload protection
- Electronic Management System (EMS)
- Anti-kickback, switches off the motor if the wheel gets jammed
- Perfect dust protection thanks to removable protective metal grille
- Ergonomic arm working posture thanks to side handle mounted at an angle
- Disc guard adjustable without tools

Also available as a boxed solo machine (Order No. 530497)

Order No. 530496

- 1x L 125 18.0-EC LD
- 1x charger CA 18.0
- 2x battery packs Li-Ion AP 18.0/5.0 Ah
- 1x disc guard for grinding, Ø 125 mm
- 1x clamping flange
- 1x clamping nut
- 1x face spanner
- 1x side handle M10
- 1x carrying case



Promotion No. 30
2.990⁰⁰

2-speed cordless drill driver DD 2G 10.8-LDBC/2.5



- Small, handy unit for light screwing and drilling work in a handy carrying case
- The electronic management system (EMS) protects the tool, extends its service life and increases efficiency
- LED cordless capacity indicator

Order No. 516155

- 1x DD 2G 10.8-LD
- 1x charger CA 10.8
- 2x battery packs Li-Ion AP 10.8/2.5 Ah
- 1x belt clip
- 1x bit storage
- 1x carrying case



Promotion No. 31
1.398⁰⁰

34 Nm

- Handy
- Narrow handle
- Very light

18 V cordless combination rotary hammer drill FHE 1-16 18.0-EC TC 2.5/kit



- Weighing just 1.37 kg, it's the lightest and most powerful 18 V cordless rotary hammer drill in its class
- Brushless motor with greater efficiency and a longer service life
- Function switch with two functions: drilling, hammer drilling,
- Electronic Management System (EMS)
- With accelerator trigger switch and continuous operation function
- Electronic quick-acting brake
- Decoupled ergonomic handle. Vibration-dampened, reduces vibrations

Also available as a boxed solo machine (Order No. 531311)

Order No. 531312

- 1x FHE 1-16 18.0-EC
- 1x charger CA 18.0
- 2x battery packs Li-Ion AP 18.0/2.5 Ah
- 1x carrying case

Promotion No. 32
2.790⁰⁰



2-speed cordless drill driver DD 2G 18.0-EC LD/2.5 kit



- Compact and efficient cordless screwdriver with extremely short head
- Electronic Management System (EMS)
- Brushless motor
- Accelerator trigger switch with switch-on lock
- Keyless chuck with Auto-Lock function
- Metal quick-clamp chuck with thrust ring and auto-lock function
- Electronic quick-acting brake
- Clockwise/anti-clockwise rotation with safety catch
- Integrated LED light with afterglow function

Order No. 519049

- 1x DD 2G 18.0-EC LD
- 1x charger CA 18.0
- 2x battery packs Li-Ion AP 18.0/2.5 Ah
- 1x belt clip
- 1x bit storage
- 1x carrying case

Promotion No. 33

2.090⁰⁰

incl. VAT € 236.81



65 Nm

2-speed cordless hammer drill driver PD 2G 18.0-EC LD/2.5 kit



- Compact and efficient cordless screwdriver with extremely short head
- Electronic Management System (EMS)
- Brushless motor
- Accelerator trigger switch with switch-on lock
- Keyless chuck with Auto-Lock function
- Metal quick-clamp chuck with thrust ring and auto-lock function
- Electronic quick-acting brake
- Clockwise/anti-clockwise rotation with safety catch
- Integrated LED light with afterglow function

Order No. 519057

- 1x PD 2G 18.0-EC LD
- 1x charger CA 18.0
- 2x battery packs Li-Ion AP 18.0/2.5 Ah
- 1x belt clip
- 1x bit storage
- 1x carrying case

Promotion No. 34

2.190⁰⁰



65 Nm

2-speed cordless hammer drill driver PD 2G 18.0-EC FS55BC/5.0



- Bit holder and 13 mm keyless chuck achieve extremely high flexibility in use
- EC technology ensures a long service life without changing the carbon brushes
- With 75 Nm, the PD 2G 18.0-EC FS55 has sufficient power for many applications

Order No. 516171

- 1x PD 2G 18.0-EC FS55
- 1x charger CA 18.0
- 2x battery packs Li-Ion AP 18.0/5.0 Ah
- 1x handle
- 1x belt clip
- 1x bit storage
- 1x carrying case

Promotion No. 35

2.780⁰⁰



75 Nm

Speeding up interior construction



Cordless drywall screwdriver DW 45 18.0-EC



Order No. 505943

- 1x DW 45 18.0-EC
- 1x bit holder UH-M 50 E6,3-C6,3
- 1x depth stop
- 1x bit storage
- 1x belt clip

INCLUDING
DB Bulk PH2 bit set
(25 bits)



INCLUDING
1x charging station 18,0 V
2x battery packs 2.5 Ah
18,0 V



Promotion No. 36
2.890⁰⁰

Screw magazine attachment M-DW 55



Order No. 531747

- 1x screw magazine attachment M-DW 55

INCLUDING
3x bits, version PH size 2,
E6,3



Promotion No. 37
1.420⁰⁰

Cordless multitool with Starlock MAX holder MT 18.0-EC



STARLOCK PLUS

STARLOCK MAX

- Oscillation angle of 2° on both sides
- With StarlockMAX tool holder
- Brushless motor
- Anti-vibration damping elements
- Tool-free tool change
- Integrated double LED lamp



Order No. 531018

- 1x MT 18.0-EC
- 1x L-BOXX® 136

INCLUDING
L-BOXX® 136



Promotion No. 38
3.390⁰⁰

INCLUDING

- 1x charging station 18.0 V
- 2x battery packs 2.5 Ah 18,0 V



Also available as a boxed solo machine (Order No. 518409) and as complete kit including 5.0 Ah batteries and charger in an L-BOXX® (Order No. 518417).



Available as accessories:
Depth and parallel stop DS MT 18.0.
(Order No. 519804).



Matching accessory kits

Kit SM BI-KIT VE3 for wood and metal

Order No. 531055

- 1x BIM wood +metal plunge-cut saw blade, 32 x 50 mm
- 1x BIM wood +metal plunge-cut saw blade, 65 x 40 mm
- 1X BIM hardwood plunge-cut saw blade, 32 x 50 mm

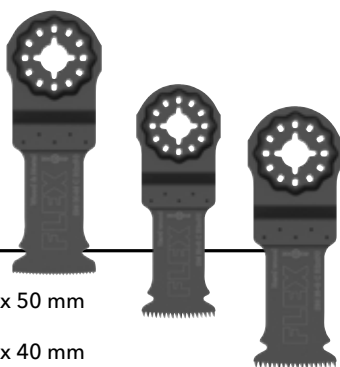

Promotion No. 39
290⁰⁰

SM/RM KIT VE3 kit for tiles

Order No. 531056

- 1x carbide technology thin-ground segmented blade, 85 mm
- 1X BIM metal plunge-cut saw blade, 32 x 50 mm
- 1x carbide technology Delta blade, 78 mm

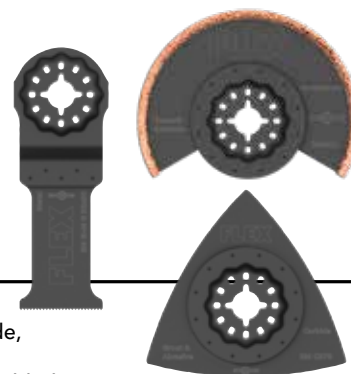

Promotion No. 40
590⁰⁰

18 V cordless work lamp WL 1000 18.0



- The LED lamp head can be swivelled through 180°+ 270°.
- LED light with 8 LED and 3 brightness levels
- Firm hold thanks to powerful integrated magnets.
- With metal handle for carrying the lamp
- Ergonomic grip surfaces with SoftGrip
- Luminous flux 200 / 500 / 1000 lm
- Colour temperature 4000 CCT



Order No. 530610

- 1x WL 1000 18.0
- 1x belt clip



Promotion No. 41
890⁰⁰

LED cordless building site spotlight with tripod TL 4000 18.0/230



4000

Lumen max.

- Powerful cordless building site spotlight with 3 brightness levels of 1000, 2000 and 4000 lumens
- The multifunctional head can be operated as a pure work light directly with an 18 V battery. Can be used fixed with a hook or mounted on a tripod
- Variable-height working range of 1.1-2.2 m with tripod
- The tripod has a 1/4" connection
- Lamp can be turned through 180°
- Multifunction control panel with LED charge level indicator, activation button, On/Off switch and USB-C charging port
- Fast set-up and stability thanks to one-button operation and tripod stand
- The building site spotlight can also be supplied with power directly via a commercially available cold appliance connection cable (**not included!**)
- Suitable for operation with 230 V or 110/120 V

Order No. 530375

- 1x TL 4000 18.0/230



Promotion No. 42
2.850⁰⁰



LED cordless building site spotlights CL 5000 10.8/18.0 and CL 10000 10.8/18.0

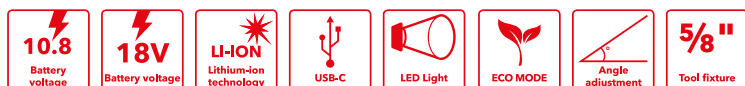

- Powerful 5000 lumens (CL 5000 10.8/18.0) or 10000 lumens (CL 10000 10.8/18.0) cordless building site spotlights with 5 brightness levels plus ECO mode.
- With memory function
- The colour temperature of 5000 kelvin corresponds to a neutral light colour
- Lamp can be turned through 120°
- Visual early-warning system: low battery charge is indicated by slightly decreasing level of brightness.
- 5/8" thread connection for tripods
- With wall mounting option
- Robust and durable for the most exacting demands
- Integrated spacer dome with cooling openings protect the lens and surfaces



5000
Lumen max.



Order No. 504602

- 1x CL 5000 10.8/18.0

Promotion No. 43
1.730⁰⁰

10000
Lumen max.



Order No. 504610

- 1x CL 10000 10.8/18.0

Promotion No. 44
2.850⁰⁰

You will find the matching tripod at www.flex-tools.com



Proformance with price advantage

The sanding all-rounder for refurbishment work. A unique compact design, effective dust extraction and handy - FLEX palm sanders with speed control are now available at an attractive introductory price.

Random orbit sander ORE 3-150-EC and ORE 5-150 EC



- Brushless motor
- Adjustable speed
- Effective dust extraction
- With disc brake
- Impact-resistant filter cartridge with replaceable PES filter
- Dust extraction connection Ø 27 mm
- Hook and loop sanding disc with multi-hole system for optimum suction, suitable for all commercially available pads Ø 150 mm



Order No. 532020

- 1x ORE 3-150 EC
- 1x medium hook & loop backing pad
- 1x PES microfilter cartridge with filter
- 1x Allen key, WAF 5

Promotion No. 45
3.315⁰⁰



Order No. 532021

- 1x ORE 5-150 EC
- 1x medium hook & loop backing pad
- 1x PES microfilter cartridge with filter
- 1x Allen key, WAF 5

Promotion No. 46
3.350⁰⁰

Delta sander ODE 2-100 EC Random orbit sander ORE 2-125 EC Orbital sander OSE 2-80 EC



- Low-vibration
- Brushless motor
- Electronic speed control with 4 settings
- Ergonomically designed, handy grip cap with Soft-Grip inlay
- Effective dust extraction thanks to integrated self-extraction with filter cartridge



Order No. 532017

- 1x ODE 2-100 EC
- 1x hook & loop backing pad
- 1x PES microfilter cartridge with filter

Promotion No. 47
2.540⁰⁰



Order No. 532018

- 1x ORE 2-125 EC
- 1x hook & loop backing pad
- 1x PES microfilter cartridge with filter

Promotion No. 48
2.540⁰⁰



Order No. 532019

- 1x OSE 2-80 EC
- 1x hook & loop backing pad
- 1x PES microfilter cartridge with filter

Promotion No. 49
2.540⁰⁰

You'll find the right industrial vacuum cleaner on Pages 26/27.



Rotary hammer drill CHE 5-40 SDS-max



- 1150 Watt hammer drill and chisel hammer in D-build with high impact energy and low vibrations
- Function switch with three functions: Hammer drilling, chiselling, chisel adjustment
- Rotation stop for chiselling
- Ideally suited for hammer drilling, diameter 40 mm in masonry and concrete for composite, injection anchor fixings and through holes.
- For chiselling work to remove plaster and tiles
- Variable speed, continuously adjustable from 1-6 with "Power Control" LED display
- Safety slip clutch: protects in the event of a jammed drill bit
- Decoupled, ergonomic handle with rubberised grip surface. Vibrations are reduced by a sprung damper and additional vibration damping between the housing and handle



Order No. 532026

- 1x CHE 5-40 SDS-max
- 1x handle
- 1x tube of grease
- 1x carrying case



Vibrations are reduced by a sprung damper and additional vibration damping between the housing and handle.



Function switch with three functions: Hammer drilling, chiselling, chisel adjustment.



INCLUDING
2-piece chisel kit

Promotion No. 50
5.660⁰⁰



Chiselling hammer DH 5 SDS-max



- Vibration-dampened rear handle
- Side handle with radial and axial rotation
- Powerful 1,050 watts
- Blows per minute 3,500 rpm
- 12 chisel settings
- Max. individual impact energy (in acc. with EPTA) 6.7 J
- Weight 5.4 kg

Order No. 532027

- 1x DH 5 SDS-max
- 1x handle
- 1x tube of grease
- 1x carrying case



INCLUDING
2-piece chisel kit



Promotion No. 51
5.360⁰⁰

Universal rotary hammer drill CHE 2-28 SDS-plus



- Light 800 watt pistol-shaped rotary hammer and drill chisel hammer
- Max. individual impact energy (in acc. with EPTA) 2.7 J
- Clockwise/anti-clockwise rotation with switchover via carbon brush reverser. As a result, almost identical torque in both directions of rotation
- Drilling with hammer function
- Drilling depth stop: for precise working
- Rotation stop for chiselling
- Max. drilling range up to 28 mm in concrete
- With accelerator trigger switch and continuous operation function
- Ideal for drilling/hammer drilling, 4-18 mm diameter in masonry and concrete for composite, anchor attachment and clearance holes and for light chiselling work to remove plaster and tiles

Order No. 532028

- 1x CHE 2-28 SDS-plus
- 1x handle
- 1x drilling depth stop
- 1x L-BOXX® 136



INCLUDING
Drilling dust adapter
SAD BS D32



Promotion No. 52
1.990⁰⁰

Giraffe® GE 7
+ Segmented sanding head MH-R D225
+ Handy-Giraffe® GCE 6-EC

Order No. 532858

- 1x Giraffe® GE 7
- 1x Handy Giraffe® GCE 6-EC
- 1x segmented sanding head with rotatable edge segment MH-R D225
- 1x clip quick-action clamping ring SH-FC 32
- 1x carrying bag



GE7

- Handy, light machine with optimum operating comfort. Low-fatigue and ergonomic working
- Innovative head change system. Grinding heads can be attached and removed with one click.
- Segmented grinding head for working on surface transitions from wall to wall and wall to ceiling.



Promotion No. 53

10.590⁰⁰



GCE 6-EC

- For smoothing plasterboard panels or upgraded insulation Styrofoam panels and for painting preparation
- Lightweight and handy for use on smaller areas, difficult to reach places
- Innovative head change system. Grinding heads can be attached and removed with one click.

Giraffe® GE 5 ECO

Order No. 474835

- 1x Giraffe® GE 5 boxed
- 1x clip adapter SAD-C D36/27 AS/NL



- Easy handling thanks to optimised balance between motor and grinding head
- Reliable power transmission, great flexibility thanks to the flexible drive shaft.

Promotion No. 54

7.640⁰⁰



Mobile workstation for wall and ceiling sanding systems GM 270

- Mobile workstation for mounting the Giraffe® types GE 5 / 7 and GDE 10, allowing sustained work performance without influencing the machine weight
- Reduced fatigue and strain significantly save the user's strength!
- Tool-free and quick Giraffe® changing thanks to clamping into a sturdy tool holder, and tool-free working height adjustment
- Optimum contact pressure on the grinding surface thanks to gas pressure spring
- Compact and handy, fits in any vehicle
- The Mobile Giraffe is ready for use quickly, and can be assembled without tools thanks to quick-action elements. The base plate can be fixed on the VCE 33/44 vacuum cleaners with an L-BOXX® attachment. Just secure the lifting rod to the folding system and clamp the Giraffe in place
- Max. working height 2.7 m
- Weight 8.0 kg

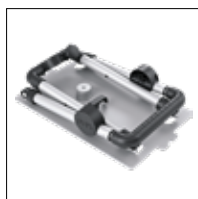

Compact and handy, fits in any vehicle.



Tool-free and quick Giraffe® changing thanks to clamping into a sturdy tool holder.

Order No. 530596

- 1x GM 270
- 1x carrying bag
- 1x L-BOXX® 136 carrying case



Promotion No. 55

5.490⁰⁰



You'll find the right industrial vacuum cleaner on Pages 26/27.



Accessories



Sanding disc, 225 mm diameter

Product	Type/grit	Order No.	Price plus VAT.
 <p>hook and loop sandpaper Xtreme Plus quality</p>	P 40	280739	949,00
	P 60	260233	949,00
	P 80	260234	949,00
	P 100	260235	908,00
	P 120	282405	908,00
	P 150	311995	908,00
	P 180	311987	908,00
	P 220	260236	908,00
 <p>Sandpaper, wall/ceiling</p>	P 24	531542	550,00
	P 40	531900	249,00
	P 60	531901	245,00
	P 80	531902	245,00
	P 100	531896	229,00
	P 120	531897	229,00
	P 150	531898	229,00
	P 180	531543	229,00
 <p>Sandpaper, extra-fine</p>	P 220	531899	229,00
	P 40	531908	395,00
	P 60	531909	395,00
	P 80	531544	395,00
	P 100	531903	379,00
	P 120	531904	379,00
 <p>Hook and loop perforated sanding paper</p>	P 150	531905	379,00
	P 180	531906	379,00
 <p>Hook and loop sanding pad</p>	P 220	531907	379,00
	K 80	260237	990,00
	K 100	260230	990,00
	A 100	281042	745,00
	A 180	281034	745,00





Sanding pad, length 290 mm

 <p>Sandpaper, extra-fine</p>	P 40	531948	395,00
	P 60	531949	395,00
	P 80	531915	395,00
	P 100	531910	379,00
	P 120	531911	379,00
	P 150	531912	379,00
	P 180	531913	379,00
	P 220	531914	379,00

Sanding discs & backing pads

	Padded adapter for GE 5, GE 5 R, GSE 5 R	KAD D225/16 S	483109	225,00
		KAD D225/16 H	483117	270,00
	Cushioned adapter for round sanding head of the Vario Giraffe® and Handy Giraffe®	KAD D225/13 S	437956	225,00
		KAD D225/13 H	483095	280,00
	Hook and loop backing pad kit, round super soft		483486	531,00

Interchangeable heads GE 7 / GCE 6-EC / GE MH 18.0-EC

	Segmented sanding head with rotatable edge segment	MH-R	457183	2.377,00
	Random orbit sanding head	MH-X	457205	2.703,00
	Round sanding head	MH-O	457175	2.153,00
	Triangular sanding head	MH-T	457191	2.377,00

Giraffe® holder for VCE 33 ... / VCE 44 ...

	Giraffe® holder	VCE-GE Fix	445185	276,00
---	-----------------	------------	--------	--------

L Class vacuum cleaner

Safety vacuum cleaner with manual filter cleaning VC 6 L MC



Order No. 532024

- 1x VC 6 L MC
- 1x suction hose 32 mm Ø x 0.5-2.5 m
- 1x flat-fold filter, Class L
- 1x fleece filter bag, Class L
- 1x hand pipe
- 1x crevice nozzle
- 1x round brush
- 1x upholstery nozzle
- 1x padded carrying strap
- 1x running gear

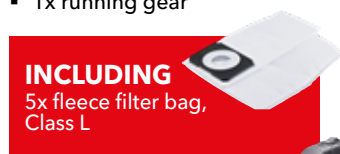

Promotion No. 56
1.390⁰⁰



Safety vacuum cleaner with manual filter cleaning VC 21 L MC



Order No. 409979

- 1x VC 21 L MC incl. accessories
- 1x extensive cleaning kit
- 5x fleece filter bags FS-F VC/E 21-26 L VE5



Promotion No. 57
2.150⁰⁰



Safety vacuum cleaner with automatic filter cleaning, S 44 L



Order No. 444146

- 1x S 44 L
- 1x suction hose with auxiliary air control
- 1X PES flat-fold filter
- 1x disposal bag
- 2x extension pipes
- 1X elbow
- 1x clip floor nozzle
- 1x crevice nozzle
- 1x upholstery nozzle
- 1x round brush
- 1x adapter
- 1X expander
- 2x hose holders

Promotion No. 58
5.890⁰⁰



Safety vacuum cleaner with automatic filter cleaning VCE 33 L AC and VCE 44 L AC



- High-performance turbine for high suction power and high negative pressure
- Permanent socket with electronic automatic On/Off
- Flow rate control via rotary switch
- Electronic fill level monitoring during wet suction
- Start-up and switch-off delay
- 15 seconds coasting empties remaining dust in the suction hose
- Dust-protected anti-static features
- Easy filter changing
- Adapter plate for fixing L-BOXXes and Tanos Systainers



VCE 33 L AC, Order No. 471186

- 1x VCE 33 L AC
- 1x anti-static suction hose Ø 32 mm x 4 m
- 1x L-BOXX® holder
- 1x flat-fold filter PES L/M/H
- 1x fleece filter bag Class L/M
- 1x PP disposal bag
- 1x adapter Ø 25-32 mm, anti-static
- 2x hose holder
- 5x fleece filter bags FS-F VCE L/M
- 1x carrying case L-BOXX® TK-L 102
- 1x extensive cleaning kit

Promotion No. 59
6.980⁰⁰



VCE 44 L AC, Order No. 471208

- 1x VCE 44 L AC
- Equipment as above

Promotion No. 60
7.090⁰⁰

M class vacuum cleaner

20 l safety vacuum cleaner with manual filter cleaning, Class M VCE 22 M MC and VCE 22 M MC V

- The high-performance turbine ensures high suction power
- With equipment socket and automatic electronic on/off switch
- With soft start and switch-off delay (5 seconds coasting)
- Selector switch suction diameter of 32 mm or 21 mm
- With flow rate control via the rotary switch
- Dust-protected anti-static features
- Safety vacuum cleaner class M, suitable for all dusts with TLV values > 0.1 mg/m³. Specially for mineral dusts and wood dusts (including beech and oak)
- Flow sensor technology monitors the flow rate

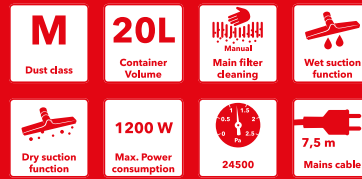

For construction site use



Order No. 519812

- 1x VCE 22 M MC
- 1x anti-static suction hose with auxiliary air control
- 1 cleaning kit



Promotion No. 61
5.890⁰⁰

For the automotive sector



Order No. 530920

- 1x VCE 22 M MC V
- 1x anti-static suction hose



Promotion No. 62
5.490⁰⁰

Safety vacuum cleaner with automatic filter cleaning VCE 33 M AC and VCE 44 M AC



- High-performance turbine for high suction power and high negative pressure
- Permanent socket with electronic automatic On/Off
- Flow rate control via rotary switch
- Electronic fill level monitoring during wet suction
- Start-up and switch-off delay
- 15 seconds coasting empties remaining dust in the suction hose
- Dust-protected anti-static features
- Easy filter changing
- Adapter plate for fixing L-BOXXes and Tanos Systainers



VCE 33 M AC, Order No. 471194

- 1x VCE 33 L AC
- 1x anti-static suction hose Ø 32 mm x 4 m
- 1x L-BOXX® holder
- 1x flat-fold filter PES L/M/H
- 1x fleece filter bag Class L/M
- 1x PP disposal bag
- 1x adapter Ø 25-32 mm, anti-static
- 2x hose holders
- 5x fleece filter bags FS-F VCE L/M
- 1x carrying case L-BOXX® TK-L 102
- 1x extensive cleaning kit

Promotion No. 63
8.950⁰⁰



VCE 44 M AC, Order No. 471216

- 1x VCE 44 M AC
- Equipment as above

Promotion No. 64
9.450⁰⁰

Maximum dust protection on the construction site

VAC 800-EC air cleaner for construction sites

Watch the video!



Very efficient

Significantly reduces the pollutant load in rooms up to 100 sq. m within a short time.

Very handy

No installation required. Set up, switch on – clean air. The filter is changed without the need for tools.

Low incidental costs

When used properly, the HEPA 14 filter can be used for up to one year. The VAC 800-EC air cleaner is specially designed for continuous operation and impresses with its very low power consumption.

Whisper mode

In special Night mode, the sound pressure level is only 38 dB (A). This means that the operating noise falls below the concentration disturbance threshold and is therefore also ideally suited to places such as classrooms.

Light weight

Weighing just 7.2 kg, the VAC 800-EC is the quietest in its class, and this makes it easy to move.

Robust construction

Specially designed for extreme conditions on construction sites. The VAC 800-EC is particularly robust, and boasts an impressive long service life.



EC Whisper Turbine ("Made in Germany")

- Long run time
- Long service life
- Low service costs
- Low noise



Tool-free "Top-Change" filter change
Thanks to simple operation of the quick-action clamping lever. Prevents unnecessary contact with spent filter cartridges.

VAC 800-EC

Order No. 532859

- 1x VAC 800-EC
- 1x HEPA filter H14
- 1x pre-filter mat G3
- 1x coarse filter G4
- 1x hose SH 125x5m C



Promotion No. 65
8.990⁰⁰



Work with negative pressure in the working area

A sluice should be installed to prevent dust from migrating into the environment outside the work area. The cleaned air is discharged from the working area via a hose or is fed back into the working area as cleaned air.

The mobile FLEX Air Cleaner can be put to use immediately and without the need to assemble anything

- Power consumption 170 watts
- Rated power consumption 1.7 - 1.45 A
- No-load speed 0-3930 /min
- Dust extraction connection Ø 125 mm
- Sound pressure level 1 m, 58 dB(A)
- Max. flow rate 544 m³/h
- Filter surface area H13 > 7.26 m²
- Fuse 10 VA
- Dimensions (L x W x H) 373 x 400 x 508 mm
- Cable length 3.5 m
- Weight 7.2 kg

Accessories

Product	Designation	Qty.	Order No.	
Hoses	SH 125 x 5 m C	1	477672	
	SH 125x6m C	1	488186	
	SH 205x7.5m C	1	500399	
Filter	Pre-filter mats G3	VFE VAC G3	10	477699
	Coarse filter G4	FE VAC G4	1	477702
	Activated carbon filter G4	FE VAC G4 AK	1	477710
	Fine dust filter F7	FE VAC F7	1	477729
	HEPA 13 filter	FE VAC H13/HEPA	1	477737
	HEPA 14 filter	FE VAC H14/HEPA	1	488194

1150-watt wet stone polisher LE 12-3 100 WET, PRCD with variable speed and PRCD switch, 115 mm



- Powerful 1150 watt motor
- Microprocessor electronics: with tachometer-generator constant speed control, soft start, overload protection and speed preselection
- GFCI operator protection circuit breaker integrated into the cable
- High torque for maximum removal performance and the best surface quality
- The water supply and control is located under the housing, making it easy to operate and ensure precise dosing. A free grip area is created directly above the polishing pad
- 2 m special hose: requires no additional hose securing.
- Quick-action brass coupling: for 1/2 water hose
- Spindle lock

Order No. 378461

- 1x LE 12-3 100 WET, PRCD
- 1x GB-S L/LE12-3
- 1x cable holder (hook & loop tape)



Promotion No. 66
5.560⁰⁰

Bushhammer for stairs LST 1503 VR



- Microprocessor electronics: with speed preselection and consistent speed control, soft start, overload protection.
- Working width adjustable: 3 stages from approx. 40 mm up to approx. 92 mm
- Stop: steplessly adjustable for precise working along the edge of the stone
- Dust extraction: for use even in occupied buildings
- The machine's 60 aggressive carbide tips take care of the job quickly precisely
- The rotating tool head is mounted in rubber, reducing noise and vibrations and increasing the drive's service life
- Grip hood directly above the tool allows the machine to be precisely guided

Order No. 259229

- 1x LST 1503 VR
- 1x stop, complete
- 1x Allen key, WAF 5
- 1x SAD D32 WS/WSK
- 1x SHV-C 32x0.5m



Promotion No. 67
10.350⁰⁰

The alternative to the small cutting bench Diamond cutting wheel for stone CS 60 WET



- High-performance motor: extra-powerful, for cutting stone and milling joints
- Stepless cutting depth adjustment from 0-60 mm, with guide rail up to 54 mm. In a 0-44 mm mitre cut, with guide rail up to 38 mm
- Stepless angle adjustment for mitre cuts from 0-45°
- Cutting marking of 0°/30°/45° on the guide table for quick orientation
- High-quality disc guard and die-cast magnesium guide plate
- Rubber motor guard prevents splash water from being directly sucked in
- Water supply: for effective cooling of the diamond tool
- Quick-action brass coupling: for 1/2" water hose
- GFCI operator protection circuit breaker integrated into the cable

Order No. 531029

- 1x diamond cutting wheel for stone CS 60 WET
- 1x key for tool changing
- 1x parallel stop
- 1x L-BOXX® 238
- 1x diamond cutting wheel with segmented cutting edge



Promotion No. 68
9.450⁰⁰

INCLUDING
GRS 160
Guide rail



Concrete Giraffe® GDE 10 kit Turbo-Jet / Thermo-Jet

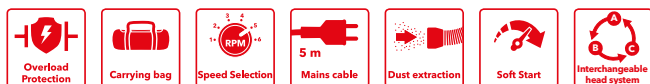

Concrete Giraffe® GDE 10 Kit Turbo-Jet

Order No. 532860

- 1x Concrete Giraffe® GDE 10
- 1x grinding head DGH-R D150 with tool holder D28 mm
- 1x grinding head DSH-R D150 with hook and loop backing pad D150 mm
- 1x hook & loop diamond sanding pad DP 30 DRY D115
- 1x anti-static suction hose SH-CF 32x4m AS/NL
- 1x diamond backing pad Turbo-Jet D150
- 1x carrying bag



Promotion No. 69
14.490⁰⁰

Concrete Giraffe® GDE 10 kit Thermo-Jet

Order No. 532861

- 1x Concrete Giraffe® GDE 10
- 1x grinding head DGH-R D150 with tool holder D28 mm
- 1x grinding head DSH-R D150 with hook and loop backing pad D150 mm
- 1x hook & loop diamond sanding pad DP 30 DRY D115
- 1x anti-static suction hose SH-CF 32x4m AS/NL
- 1x diamond backing pad Thermo-Jet D150
- 1x carrying bag



Promotion No. 70
14.490⁰⁰



The grinding heads DGH-R D150 and DSH-R D150 are included as standard in the scope of delivery



Cordless circular saw CS 62 18.0-EC/5.0 kit



- Powerful feed
- Cutting depth of max. 62 mm

Order No. 513326

- 1x cordless circular saw CS 62 18.0-EC
- 2x battery packs Li-Ion AP 18.0/5.0 Ah
- 1x charger CA 10.8/18.0
- 1x saw blade Z 24-WZ
- 1x dust bag
- 1x suction adapter
- 1x L-BOXX® 374 carrying case
- 1x adapter for guide rail GR-A CS 62

Promotion No. 71
6.390⁰⁰



Flexible adapter for rail system
- Tool-free assembly
- Cuts of 0°-50° on the FLEX rail
- Can be used for other rail systems

INCLUDING
GRS 160 guide rail

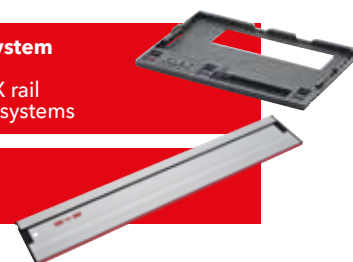

You'll find the right industrial vacuum cleaner on Pages 26/27.

Compact renovation grinder for sanding up to edges LDE 16-8 125 R, Turbo-Jet II kit

- Electronics with speed stabilisation, soft start, overload protection and temperature monitoring
- Reliable 1600 watt high-power motor
- Steplessly adjustable no-load speed 4500-7800/min
- Anti-kickback, switches off the motor if the wheel gets jammed
- Disc guard with pivoting segment for sanding up to the wall
- Steplessly-adjustable, vibration-dampened ergonomic handle
- FLEX clip hose connection for Ø 32 mm snap coupling included in the basic package
- Recessed spindle lock to prevent accidental actuation
- Ideally suited to working on walls, ceilings and floors. Efficient and economical thanks due to optimum machine and sanding disc matching

Order No. 513474

- 1x LDE 16-8 125 R
- 1x diamond backing pad Turbo-Jet II
- 1x dust extraction guard with brush ring
- 1x bail handle
- 3x cable holders
- 1x Allen key, WAF 4
- 1x face spanner
- 1x L-BOXX® 238 carrying case



Also available as LD 16-8 125 R, Turbo-Jet II kit with constant speed, (Order No. 504939)

INCLUDING

Diamond backing pad Scred-Jet Ø 125 mm (Backing pad for abrasive materials)



Promotion No. 78

6.390⁰⁰

Powerful 2400 watt renovation grinder for surfaces, 180 mm LD 24-6 180, Turbo-Jet kit

- Elastic rubber suction ring with low-wear metal ring
- Dust extraction protects against abrasive dust
- Soft start for a safe start
- Restart protection after a power failure
- Dust extraction guard with continuous height adjustment
- Extraction nozzle 32 mm external Ø
- Very well suited to material removal from large areas
- Sanding plates of heights 22 mm to 28 mm are suitable.
- With steplessly adjustable, vibration-dampened ergonomic handle

Order No. 513482

- 1x LD 24-6 180
- 1x Turbo-Jet diamond grinding disc, Ø 180 mm
- 1x dust extraction guard with rubber suction ring
- 1x suction adapter
- 1x clamping nut M 14
- 1x clamping flange WAF 17
- 1x Allen key, WAF 6
- 1x face spanner
- 1x bail handle
- 3x cable holders
- 1x carrying case



Ø 180 mm



INCLUDING
PKD backing pad Ø180 mm



Promotion No. 79

8.390⁰⁰

RETECFLEX the universal tool for renovation, refurbishment and modernising RE 16-5 115, pointed scouring head kit

- Universal tool system that can be adapted for many refurbishment and modernisation applications. Compact, handy and perfectly suited to machining smaller areas and the edges of large areas
- Speed preselection, speed stabilisation by means of tachogenerator, soft start, restart interlock after power failure, overload protection and temperature monitoring
- Anti-kickback
- Special gearbox: special gear reduction provides high torque in the medium and lower speed range
- With steplessly adjustable, vibration-dampened ergonomic handle
- FLEX clip system. No adapter and reducing sleeves required
- Dust extraction guard: with stepless height adjustment
- Spindle lock

Order No. 513504

- 1x RE 16-5 115
- 1x pointed scouring head
- 1 dust extraction guard for sanding
- Ø 115 mm brush ring
- 1x base for scouring Ø 80 mm
- 1x backing pad Ø 115/M14 hook and loop, bowl
- 1 corundum Ø 115 sanding paper kit
- 1x bail handle
- 1x ring spanner, WAF 13
- 1x Allen key, WAF 4
- 3x fastening screws, M 8
- 1x L-BOXX® 238 carrying case



INCLUDING
Diamond backing pad Scred-Jet
PCD grinding disc



Promotion No. 80

9.390⁰⁰

You'll find the right industrial vacuum cleaner on Pages 26/27.

High precision – line after line

Self-levelling cross-line laser ALC 2/1-G/R



- Individually switchable horizontal and vertical laser line
- Anti-reflection lenses
- Range up to 50 metres/up to 70 metres with receiver
- Self-levelling can be switched off
- Simple operation
- Integrated Li-polymer rechargeable battery



Order No. 530443

- 1x ALC 2/1-G/R
- 1x magnetic holder
- 1x carrying bag
- 1x USB cable
- 1x USB charger

Self-levelling cross-line laser ALC 3/1-G/R

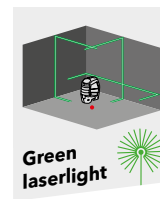

- With one horizontal and two vertical laser lines at a 90° angle plus plumb (red laser), individually switchable.
- Range up to 50 metres/up to 70 metres with receiver
- Anti-reflection lenses
- Battery operating period of over 6 hours



Order No. 530444

- 1x ALC 3/1-G/R
- 1x magnetic holder
- 1x carrying bag
- 1x USB cable
- 1x USB charger

INCLUDING

Tripod LKS 65-170 F 1/4



Promotion No. 72

2.590⁰⁰

INCLUDING

Tripod LKS 65-170 F 1/4



Promotion No. 73

3.290⁰⁰

360° cordless line laser ALC 3/360-G/R 10.8 kit



- Receiver mode
- One horizontal and two vertical 360° laser lines, individually switchable
- Plumb function
- Anti-reflection lenses
- Range up to 100 m, with receiver up to 120 m
- Self-levelling function can be switched off
- 3 brightness levels
- Dust-proof and splash-proof
- Optical warning signal when self-levelling range is exceeded

Order No. 532862

- 1x ALC 3/360-G/R 10.8
- 1x laser target plate and glasses
- 1x laser universal holder
- 1x charger CA 10.8
- 1x rechargeable battery 2.5 Ah AP 10.8/2.5
- 1x carrying case L-BOXX® 136

Promotion No. 74

6.450⁰⁰

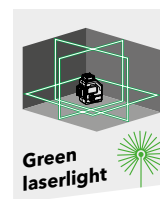

INCLUDING

Tripod LKS 65-170 F 1/4



Safety information! FLEX laser measuring instruments comply with all international safety standards. They comply with laser class 2 or 2M according to DIN EN 60825-1: 2001-11 (wavelength 635-670 nm, output power < 1mW) and do not harm the eyes or skin when used as directed. Nevertheless one should never look directly into the laser beam when using laser measuring devices.

Laser rangefinder ADM 100 G up to max. 100 m

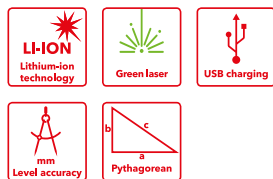

- Green laser for fast and precise measurements
- Length, surface, volume and indirect measurements
- Permanent angle measurement
- Up to 99 values can be stored with the memory function
- Continuous measurement mode
- Unit/sound button: Silent or with tone and setting of the required measuring unit
- Illuminated four-line display
- Housing protected against dust and splash water
- 1/4" connecting thread for tripods
- Operation possible with AAA 1.5 V batteries or a rechargeable battery



ADM 100 G
Order No. 518964

- 1x lithium ion battery
- 3x AAA 1.5 V batteries
- 1x USB in micro-USB cable
- 1x protective bag

Promotion No. 75
2.099⁰⁰

Laser rangefinder ADM 70 G up to max. 70 m

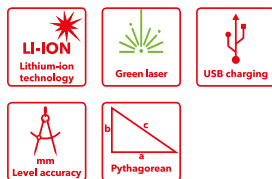

- Green laser for fast and precise measurements
- Length, surface, volume and indirect measurements
- Permanent angle measurement
- Up to 99 values can be stored with the memory function
- Continuous measurement mode
- Unit/sound button: Silent or with tone and setting of the required measuring unit
- Illuminated four-line display
- Housing protected against dust and splash water
- 1/4" connecting thread for tripods
- Operation possible with AAA 1.5 V batteries or a rechargeable battery



ADM 70 G
Order No. 518956

- 1x lithium ion battery
- 3x AAA 1.5 V batteries
- 1x USB in micro-USB cable
- 1x protective bag

Promotion No. 76
1.622⁰⁰

Laser rangefinder ADM 30 Smart up to max. 30 m

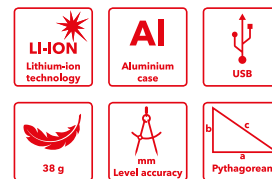

- Rapid determination of dimensions indoors
- Simple operation
- Length, surface area and volume calculation
- Indirect height measurement
- Continuous measurement mode
- Units can be switched between m/mm, inch/feet
- Integrated rechargeable battery
- Automatic switch-off
- Illuminated display
- Dust-proof housing



ADM 30 Smart
Order No. 504599

- 1x ADM 30 Smart
- 1x hand strap
- 1x USB cable

Promotion No. 77
420⁰⁰

Safety information! FLEX laser measuring instruments comply with all international safety standards. They comply with laser class 2 or 2M according to DIN EN 60825-1: 2001-11 (wavelength 635-670 nm, output power < 1mW) and do not harm the eyes or skin when used as directed. Nevertheless one should never look directly into the laser beam when using laser measuring devices.

Causing a real stir

FLEX professional mixers are causing a stir on the market. Secure an ergonomically optimal solution for clean, powerful and fast mixing on the construction site now. The ideal introductory offer for painters, plasterers or bricklayers.

2 helical paddles included with every unit

**1x WR2 ...x600 M14
1x WR3R ...x600 M14**



1010 watt 1-speed mixer MXE 1000

- For mixing applications up to 40 kg
- Full-wave electronics: with soft start, temperature monitoring, overload protection and stepless speed control via the accelerator trigger switch
- No-load speed 0 - 780/min



Order No. 531035

- 1x 1-speed mixer MXE 1000
- 1x helical paddle WR2 120x600 M14
- 1x helical paddle WR3R 120x600 M14

Promotion No. 81
1.790⁰⁰



1600 watt 2-speed mixer MXE 1602

- For mixing applications up to 90 kg
- Sturdy 2-speed gearbox: large size and optimum gear ratio - for speeds to suit the material and a high torque
- with soft start, temperature monitoring, overload protection and stepless speed control via the accelerator trigger switch
- Comfortable 3-setting switch accessible from the handle position without interrupting work, protected by a rubber grommet

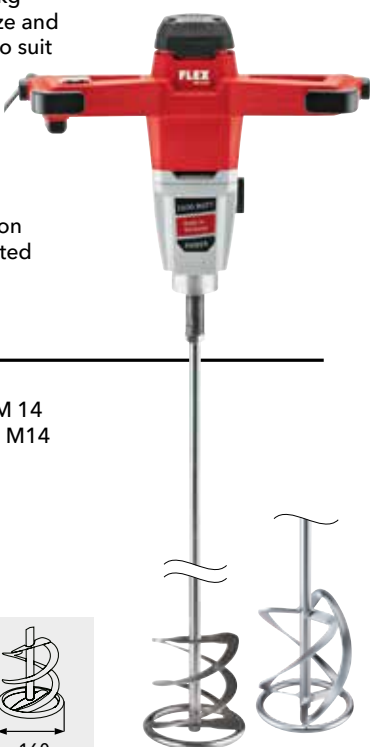

Order No. 531037

- 1x 2-speed mixer MXE 1602
- 1x helical paddle WR2 160x600 M 14
- 1x helical paddle WR3R 160x600 M14

Promotion No. 83
3.490⁰⁰



1200 watt 2-speed mixer MXE 1202

- For mixing applications up to 60 kg
- Full-wave electronic control: with soft start, temperature monitoring, overload protection, and with continuous speed control via the accelerator trigger switch
- 3-setting switch / Setting 1: Cleaning, Setting 2: Slow stirring, Setting 3: Mixing
- No-load speed, 1st Gear 0 - 210 / 325 / 530/min
- No-load speed, 2nd Gear 0 - 320 / 490 / 780/min

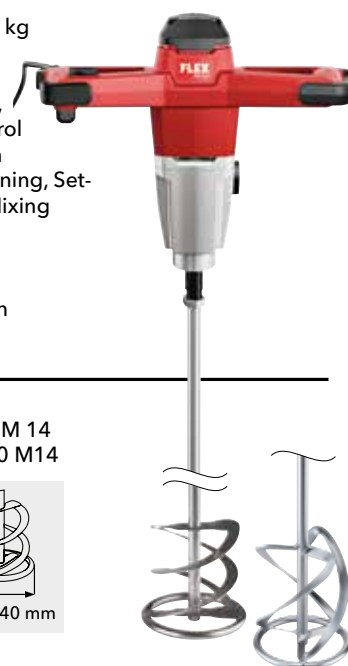

Order No. 531036

- 1x 2-speed mixer MXE 1202
- 1x helical paddle WR2 140x600 M 14
- 1x helical paddle WR3R 140x600 M14

Promotion No. 82
2.590⁰⁰



18 V cordless 2-speed mixer with MXE 18.0-EC 3-setting speed switch



- For mixing applications up to 30 kg
- Electronic Management System
- Accelerator trigger switch
- Robust 2-speed gearbox
- 3-setting switch / Setting 1: Cleaning, Setting 2: Slow stirring, Setting 3: Mixing
- No-load speed, 1st Speed 0 - 210 / 325 / 530 rpm
- No-load speed, 2nd Speed 0 - 320 / 490 / 780 rpm



Order No. 532031

- 1x cordless 2-speed cordless mixer MXE 18.0-EC
- 1x charger CA 10.8/18.0
- 2x battery packs Li-Ion AP 18.0/5.0 Ah
- 1x helical paddle WR2 120x600 M14
- 1x helical paddle WR3R 120x600 M14



Promotion No. 84
5.290⁰⁰



2600 watt angle grinder L 26-6 230 TK-S



- Motor: heavy-duty and very efficient for strong grinding performance
- Soft start, restart protection after a power failure, overload protection, CDC constant speed control
- Anti-kickback
- SoftVib handle reduces vibrations, can be mounted in three positions
- Rear handle with soft insert can be rotated 90° to the clockwise and anti-clockwise for an optimum working posture
- Spindle lock



Order No. 466239

- 1x L 26-6 230 TK-S
- 1x carrying case
- 1x SDS-Clic quick-release nut M 14
- 1x diamond cutting wheel, standard concrete Ø 230 mm

Ø 230



Promotion No. 85
2.490⁰⁰

Dust extraction guard and diamond cutting system DCG L 26-6 230 Kit

- Ready to go straight away, angle grinder with ready-fitted dust extraction guard in the case. Universal diamond cutting wheel 230 mm including
- Powerful angle grinder L 26-6 230 with soft start, restart protection, overload protection, CDC constant electronics, anti-kickback function
- Fully encapsulated dust extraction guard for efficient dust extraction
- Direct connection via Flex Clip system
- Base plate with rollers for easy feed. Can be used with or without guide rail
- Depth stop with scale for presetting the cutting depth and any desired start of cut (plunge cut) with and without guide rail (max. 55 mm with or 60 mm without rail).
- Side handle, can be fitted on either the right or left



Order No. 494674

- 1x L 26-6 230 angle grinder
- 1x dust extraction guard DCG AG 230
- 1x diamond cutting wheel, universal Ø 230 mm
- 3x DCG AG kit rubber strip
- 1x DCG AG 230 spacer ring L26/24/22
- 1x SoftVib handle
- 1x clamping flange
- 1x clamping nut M 14
- 1x Allen key, WAF 6
- 1x face spanner BL 5
- 1x guide rail GRS 80
- 1x carrying case with inlay



Ø 230

Promotion No. 86
5.763⁰⁰

Dust extraction guard DCG AG 230

Detachable dust extraction guard with efficient dust extraction for precise cuts when working with diamond cutting wheels in conjunction with 230 mm angle grinders. Extremely stable, the stabiliser element prevents distortion caused by the side weight of the angle grinder. Base plate with rollers for easy feed, the side handle can be fitted on either the left or right. Incl. suction connection for FLEX clip system and adapter for guide rail. Depth stop with scale for presetting the cutting depth for use with or without a guide rail. Maximum cutting depth 60 mm.

Order No. 471895

- 1x dust extraction guard DCG AG 230



Promotion No. 87
1.826⁰⁰

800 watt angle grinder
L 811 125

Ø 125



- Comprehensive dust protection for motor and gearbox
- Restart protection after a power failure
- Longer service life thanks to optimised cooling and modified carbon brush geometry
- Light, ergonomic design, short and very handy
- Disc guard adjustable without tools



Order No. 494682

- 1x L 811
- 1x disc guard 125 Ø grinding
- 1x handle
- 1x clamping flange
- 1x clamping nut M 14
- 1x face spanner

Promotion No. 88

570⁰⁰

1000 watt angle grinder
L 1001 125

Ø 125



- Restart protection
- Motor: heavy-duty and very efficient for strong grinding performance
- Extremely light and handy
- Compact, streamlined and ergonomic design
- Disc guard adjustable without tools



Order No. 438340

- 1x L 1001 125
- 1x disc guard 125 Ø grinding
- 1x handle
- 1x clamping flange
- 1x clamping nut M14
- 1x face spanner

Promotion No. 89

819⁰⁰

1400 watt angle grinder
L 1400 125

Ø 125



- Soft start, restart protection after a power failure, temperature monitoring, CDC constant speed control
- Motor: heavy duty with a high level of efficiency
- Longer service life thanks to optimised cooling and carbon brush geometry
- Comprehensive dust protection for motor and gearbox
- Ergonomic arm working posture thanks to side handle mounted at an angle
- Tool-free adjustable guard hood with clamping lever
- Lockable slide switch
- Spindle lock



Order No. 492329

- 1x L 1400 125
- 1x disc guard 125 Ø grinding
- 1x handle
- 1x clamping flange
- 1x clamping nut M 14
- 1x face spanner

Promotion No. 90

1.150⁰⁰

2200 watt angle grinder
L 2200 230

Ø 230



- Durable motor and gearbox housing. The stable and robust steel gearbox and the spindle bearing protected by a metal cap increase reliability and service life.
- Rear shaft handle with soft padding for secure grip
- Switch with safety catch and lock
- Restart protection after a power failure
- Soft start for a comfortable and smooth start
- Spindle lock
- Tool-free adjustable guard hood with clamping lever
- Cutting guard (389625) or cutting guard cover (446068) as an optional accessory



Order No. 492280

- 1x L 2200 230
- 1x disc guard 230 Ø grinding
- 1x handle
- 1x clamping flange
- 1x clamping nut M 14
- 1x face spanner

Promotion No. 91

1.320⁰⁰

900 watt angle grinder LE 9-11 125

Ø 125



- With speed stabilisation, speed control, soft start, restart interlock after power failure, overload protection
- Variable speed adjustment (6 settings)
- Motor: heavy duty with a high level of efficiency
- Compact, streamlined and ergonomic design
- Anti-kickback, switches off the motor if the wheel gets jammed
- Disc guard adjustable without tools



Order No. 512818

- 1x LE 9-11 125
- 1x disc guard
125 Ø grinding
- 1x handle
- 1x clamping flange
- 1x clamping nut M 14
- 1x face spanner

Promotion No. 92
1.390⁰⁰

INCLUDING
FixTec quick-clamp
nut M 14



1700 watt angle grinder LBE 17-11 125

Ø 125

Variable speed



- Also with variable speed 2800-11,500/min
- Heavy-duty, highly-efficient motor
- Longer service life thanks to optimised cooling and modified carbon brush geometry
- Comprehensive dust protection for motor and gearbox
- With mechanical brake, stops the tool in 3.5 seconds
- Disc guard adjustable without tools
- Lockable slide switch
- SoftVib handle with integrated clamping nut wrench and vibration damping



Order No. 502022

- 1x LBE 17-11 125
- 1x disc guard
125 Ø grinding
- 1x SoftVib handle
- 1x clamping flange
- 1x clamping nut M 14

Promotion No. 93
2.750⁰⁰

INCLUDING
1200 watts
Angle grinder
L 12-11 125



2200 / 800 watt angle grinder L 2200 230 / L 811 125

Ø 230

Ø 125

2200 watt angle grinder L 2200 230

- Max. grinding tool Ø 230 mm
- No-load speed 6500 /min
- Power consumption 2200 watts
- Tool holder M 14
- Clamping collar Ø 64 mm
- Cable length 4.0 m
- Weight 5.8 kg

800 watt angle grinder L 811 125

- Max. grinding tool Ø 125 mm
- No-load speed 12000 /min
- Power consumption 800 watts
- Tool holder M 14
- Clamping collar Ø 40.3 mm
- Cable length 4.0 m
- Weight 2.0 kg



Order No. 492302

- 1x L 2200 230
- 1x L 811 125
- 1x carrying case

Promotion No. 94
1.990⁰⁰

2200 / 1010 watt angle grinder L 2200 230 / L 1001 125

Ø 230

Ø 125

2200 watt angle grinder L 2200 230

- Max. grinding tool Ø 230 mm
- No-load speed 6500 /min
- Power consumption 2200 watts
- Tool holder M 14
- Clamping collar Ø 64 mm
- Cable length 4.0 m
- Weight 5.8 kg

1010 watt angle grinder L 1001 125

- Max. grinding tool Ø 125 mm
- No-load speed 10000 /min
- Power consumption 1010 watts
- Tool holder M 14
- Clamping collar Ø 40.3 mm
- Cable length 4.0 m
- Weight 2.2 kg



Order No. 492310

- 1x L 2200 230
- 1x L 1001 125
- 1x carrying case

Promotion No. 95
2.090⁰⁰

Cordless TRINOXFLEX kits

18 V cordless belt file FBE 30 18-EC

- Brushless motor, greater efficiency, longer service life
- Unique tool attachment with quick-release coupling for changing the four system attachments without using tools
- Head can be swivelled through 140°. Sanding arms can be used with 9 mm or 30 mm
- Sanding arm adjustable for belt lengths of 520 mm and 533 mm
- Sanding arm working length up to approx. 12 cm
- Change sanding belt: quickly and without tools

Order No. 532117

- 1x sanding attachment, belt file BF 140
- 2x sanding belts ZIRCOFLEX P60
- 2x sanding belts ZIRCOFLEX P120



Promotion No. 96
5.990⁰⁰

18 V cordless pipe belt sander BRE 50 18-EC

- Brushless motor, greater efficiency, longer service life
- Unique tool attachment with quick-release coupling for changing the four system attachments without using tools
- High-quality sanding arm with spring suspension: made of light alloy with 2 deflection rollers. For optimum wrap-around of pipes up to max. 270°
- Change sanding belt: quickly and without tools

Order No. 532118

- 1x sanding attachment, pipe belt BR 50
- 2x sanding belts ZIRCOFLEX P60
- 2x sanding belts ZIRCOFLEX P120



Promotion No. 97
6.990⁰⁰

18 V cordless fillet weld sander LKE 152 18-EC

- Brushless motor, greater efficiency, longer service life
- Unique tool attachment with quick-release coupling for changing the four system attachments without using tools
- For precision work on surfaces, sanding work in particularly tight angles, corners and hard-to-reach places
- Microprocessor control: Speed preselection, speed stabilisation by means of tachogenerator, soft start, restart interlock after power failure, overload protection and temperature monitoring

Order No. 532120

- 1x sanding attachment for fillet weld BS 152



Promotion No. 98
7.990⁰⁰

18 V cordless burnisher BSE 50 18-EC

- Brushless motor, greater efficiency, longer service life
- Unique tool attachment with quick-release coupling for changing the four system attachments without using tools
- Adjustable burnishing attachment, allows working close up to the edge, also suitable for narrow rollers, incl. parallel stop. Tool-free grinding tool change via patented quick-change system
- For optimum finishing of various materials, for burnishing, texturing, polishing, brushing, smoothing, de-rusting and deburring steel and stainless steel surfaces

Order No. 532119

- 1x sanding attachment for burnishing BS 50



Promotion No. 99
4.990⁰⁰

You'll find the right batteries and chargers on pages 10/11.



Further information about metalworking with the TRINOXFLEX system can be found on our website!

1400 watt metal-cutting circular saw CSM 4060



- Exact sawing of metal without cooling fluid
- Chip collection container with viewing window:
 - Large dimensions
 - Can be emptied without using tools
- Guide plate adjustable without using tools, infinitely variable sawing depth adjustment up to 63 mm
- Special carbide-tipped saw blades: nearly burr-free cuts, trimming threaded bars possible without recutting the thread.
- Switch with safety catch and lock
- Maximum cutting depths:
 - Solid material / flat steel: 6 millimetres
 - Round material: 20 mm
 - Hollow sections: 63 mm

Order No. 506044

- 1x CSM 4060
- 2x carbide saw blades for steel
- 1x parallel stop
- 1x combination wrench
- 1x protective goggles
- 1x carrying case



Promotion No. 100

5.820⁰⁰



INCLUDING

800 watt
angle grinder
L 811 125



850 watt metal-cutting band saw with swivelling saw frame SBG 4910



- Can be used with sawing bench or guided manually
- Stepless and tool-free adjustment of the cutting angle from 0° to 45°
- 3-point ball-bearing saw blade guide for optimum blade control

Order No. 406236

- 1x SBG 4910
- 1x parallel stop
- 1x bimetal saw blades
- 1x chuck jaws SBG-SP 10 VE2



Promotion No. 101

4.990⁰⁰





18 V variable-speed cordless straight grinder DGE 25 18.0-EC



- Very slender and light machine for optimum handling. Only 147mm grip circumference
- Speed preselection in 4 steps (10,000 / 15,000 / 20,000 / 25,000 rpm)



INCLUDING
P-Kit 55 R

Also available in an L-BOXX®
(without battery and charger)
(Order No. 518972).

Order No. 532115

- 1x collet 6 mm Ø
- 1x open-end spanner a/f 17



Promotion No. 102
4.990⁰⁰

Variable-speed cordless straight grinder DGE 8 -32



- Powerful and robust 800 W motor
- Variable speed 10600 - 32000 rpm
- Slender and light machine for optimum handling.
- 43 mm clamping neck for stationary fixing or handle attachment
- Handle protective cover for safe machine guiding
- Lockable, On/Off switch at the side

Order No. 522279

- 1x collet 6 mm Ø
- 1x open-end spanner a/f 17



Promotion No. 103
3.519⁰⁰



Bright prospects

Does your heart beat for perfect paint surfaces? Then FLEX Automotive Systems is definitely the right place for you. Here you'll find everything to do with polishing technology.



The features of the machines correspond to the usual basic features. Subject to VAT changes, technical changes, price changes and errors.
All prices in bold are recommended prices plus VAT.



Your FLEX retailer: